

Frascati, November 30, 1993

Note: **MM-2**

ACCUMULATOR KICKER MAGNETIC MEASUREMENTS

S. De Simone, A. Drago and A. Ghigo

1. Introduction

In this note we report the magnetic measurements of the DAΦNE Accumulator kicker magnet final prototype.

The kicker magnets allow the injection of the LINAC beam into the Accumulator ring with a repetition rate up to 50 pps and extraction of the damped beam from the accumulator in order to inject in the DAΦNE Main Rings at 1÷2 pps [1].

The integrated magnetic field that the kickers must provide for injection and extraction are given in Ref. 2.

In the Accumulator there are four kickers, as shown in Fig. 1, two placed close to the radio frequency cavity (K3, K4) and two in the opposite straight section (K1, K2). The two pairs have different lengths; K1 and K2 are .845 m long; k3 and k4 are .55 m long. The longer ones must provide higher integrated magnetic field (~120-140 G*m), determined by extraction requirements.

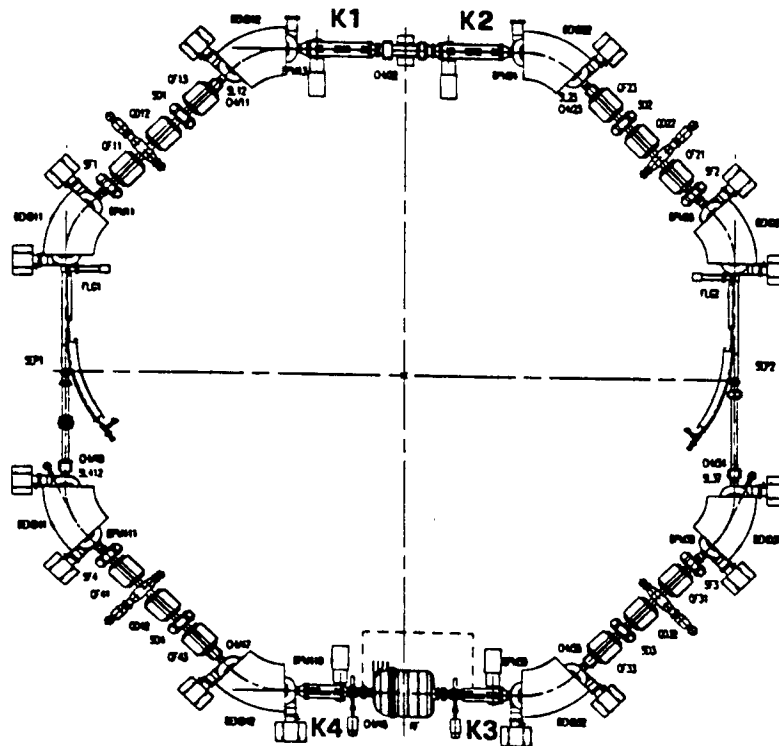

Fig. 1 - Accumulator Layout.

The kicker design and the first prototype, including the pulsed power supply, were realized and tested in the Pulsed Magnet Laboratory [3].

The final prototype of the longer kicker was realized by CERAMEX under design and engineering specification [4] of the Mechanical Engineer Section of the Accelerator Division (see Fig. 2).

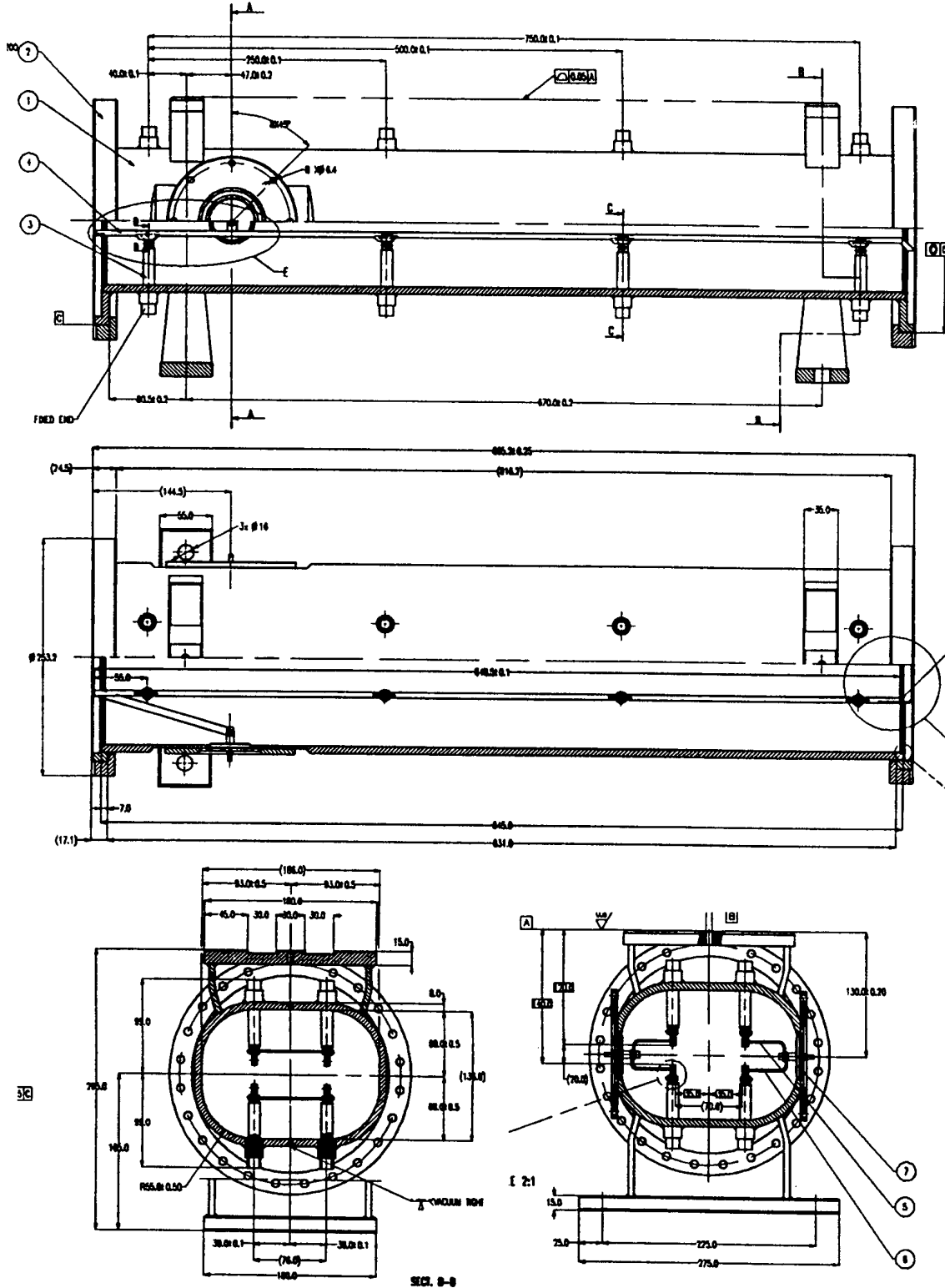

Fig. 2 - Longer kicker.

2. Experimental Set-Up

The magnet prototype was installed on a bench in the pulsed magnet laboratory and connected to the power pulser as in the final configuration. The High Voltage (HV) power supply is located, not far from the bench, in a rack together with the trigger unit. A descriptions of the magnet and pulser is reported in Ref. 3.

The magnetic measurements were performed by introducing a probe copper coil in which the kicker time-varying linked magnetic field flux induces a voltage. The voltage is read by a digital oscilloscope after passive integration.

The magnet was not under vacuum to allow simple introduction and movement of the probe, and higher voltage on the magnet coil can cause electrical discharge. Therefore, all the measurements were performed at fixed current (1000 A) with the pulser voltage not in excess of 12 KV.

The most interesting measurement is the field/current characteristic, that permits to extrapolate the current required from the pulser to achieve the required field.

We performed three kind of magnetic measurements:

- 1) The integrated magnetic field, to assess the pulser current needed for the maximum beam deflection angle.
- 2) The field map on a plane perpendicular to the beam motion (X-Y), which is necessary since the beam does not pass in the magnet center (field uniformity).
- 3) The longitudinal field distribution, of particular interest in the fringe region in order to optimize the connection between kicker bars and vacuum feed-through.

3. Measurement coils

We employed three different probes for the various measurements:

- a) To measure the integrated magnetic field, a long coil was realized with a strip of double-sided printed circuits board. It is a controlled thickness fiberglass dielectric support with copper foils bonded on both sides of the dielectric material with an epoxy resin. The coil is 1.5 mm wide and 1 m long.
- b) For the X-Y map a machined fiber glass board is the support for a silvered copper wire, the coil surface is $4.9 \times 100 \text{ mm}^2$.
- c) In the fringe field measurements a 10 mm long, 1.5 mm wide 10 turns probe has been used.

The probe signal is integrated before acquisition by an RC circuit.

4. Coil motion system

In the integrated field measurements, the long coil is aligned in the kicker by two PVC supports placed at both ends of the vacuum chamber. It is possible to move the coil in 5 mm steps on the horizontal plane at fixed vertical coordinate $Y=0$.

In the field map measurements the probe fiberglass support is mounted on a two axis translation stage (CINEL) placed outside the vacuum chamber. These linear movements are provided by two stepping motors (Superior Electric) driven by SLO-SYN 230T units. These are remote controlled by digital I/O interface (National In. NB-TIO-10) inserted in the Macintosh II NuBus, which generates the pulse train that permits a controlled displacement.

The same arrangement is used for the longitudinal displacements by rotating one of the translation stages.

Accurate alignment procedure was necessary to ensure the reproducibility of the measurement. A theodolite was employed to align the kicker magnet chamber with respect to the measurement bench and the measurement coil with respect to the mechanical axis of the vacuum chamber (the internal bars are joined the chamber). The maximum vertical and horizontal displacement versus the programmed movements along the measurements range was also checked to within 1%.

5. Acquisition system

The data acquisition system is schematically shown in Fig. 3.

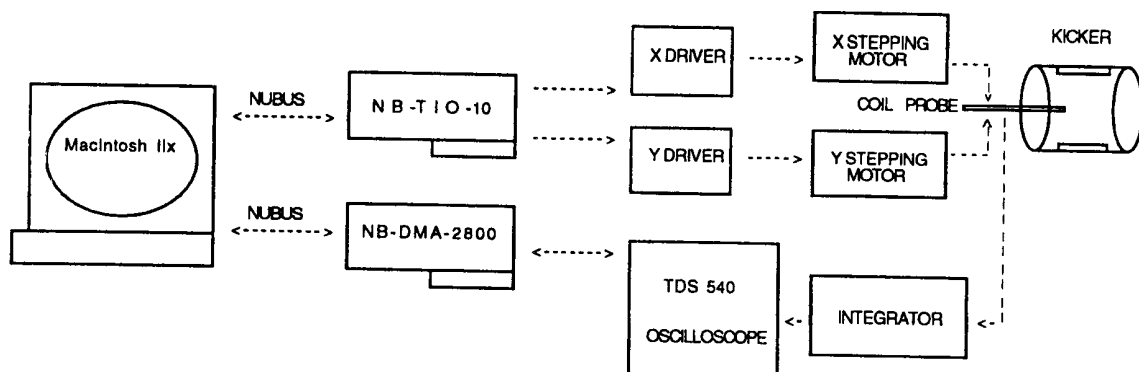

Fig. 3 - Data acquisition and stepping motors control scheme.

The integrated voltage pulse on the probe coil is displayed by a digital oscilloscope Tektronix TDS540, which performs the measurement of the peak value.

The multipurpose National In. board DMA 2800 receives data via GPIB and sends them via NuBus interface to a Macintosh II, where an acquisition program is running. This program, written in LABVIEW, performs the following tasks:

- it sends a progressive shifting command to the stepping motors to scan the interested area at 1 mm steps;
- it waits some seconds to stabilize the measurement setup;
- it queries the average peak value from the oscilloscope;
- it stores the acquired value in a matrix format for off line analysis;
- it displays the collected values for each x-axis scansion.

At the end of the main loop the probe is automatically moved to the starting position.

Other tasks performed by the program are single probe shifting on y or x axis, in both direction, and single oscilloscope reading.

6. Results

We calibrate the integrator with a continuous sinusoid of the same frequency of the kicker pulse current (2.27 MHz) and with a simulated signal from the kicker probe (half period sinusoid) as shown in Fig. 4; the integrator attenuation is : $K = (10.7 \pm 0.2) \cdot 10^{-6}$ sec.

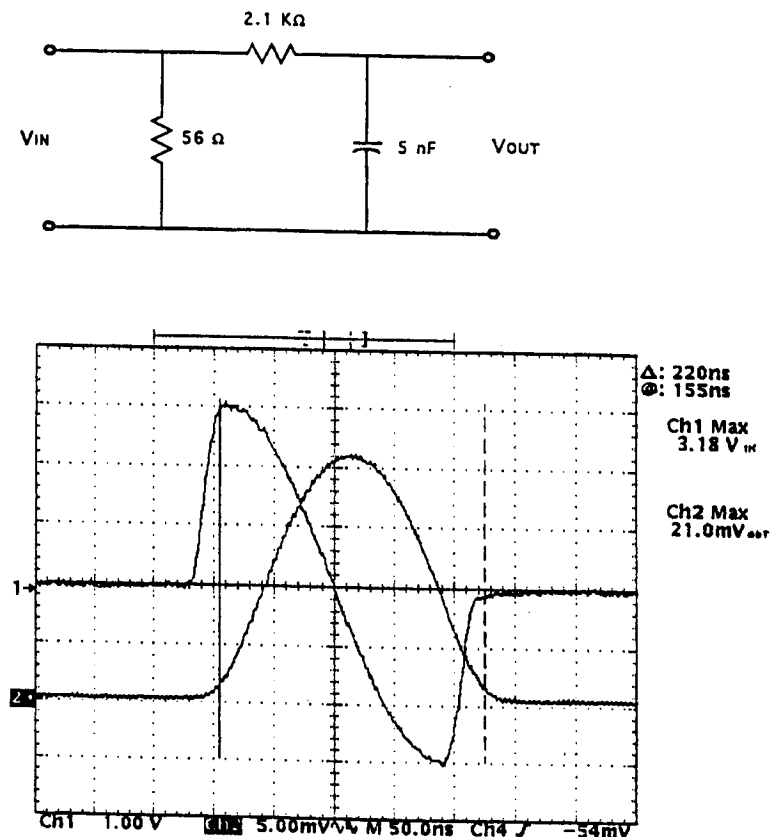

Fig. 4 - Integrator circuit and its response to a half sinusoidal pulse.

The maximum relative error on the probe voltage acquisition during the field measurements is about 1%.

The error on the probe width is ~ 0.1 mm.

- 1) With the short coil (b) we measure the field-current characteristic B_{MAX}/I at the kicker center. In fact at fixed current 1 KA the measured field is:

$$B_{MAX} = K \frac{V_{PRO}}{S_{PRO} L_{PRO}} = 74 \pm 3 \text{ [G]}$$

where V_{PRO} , S_{PRO} and L_{PRO} are the voltage, the width and the length of the measurement coil respectively, K the integrator constant. Then B_{MAX}/I is 74 ± 3 [G/KA].

We repeat the measurement with the long coil (a) at the same current I in the kicker; this provides the integrated magnetic field that is related to the beam deflection:

$$\int_L B dl = \frac{KV_{PRO}}{S_{PRO}} = 56 \pm 5 \text{ [G} \cdot \text{m]}$$

The ratio of these measurements gives us the effective magnetic length, which is about $L_M = 750$ mm.

This length is different from the coil mechanical length of 848 mm; this is due to the connection between feed-through and bars adopted in order to maximize the coils length within the available space. In this connection the current, which flows in the opposite direction with respect to the coils, reduces the magnetic field at the center as shown by the field longitudinal measurements (see fringing field measurements).

In the final construction the connections will be modified in order to reach a higher efficiency; a shorter welding will increase the useful length and farther connections will increase the field at the end of the coils.

With these improvements the pulser must provide ~ 2.6 KA to achieve the requested field at extraction.

- 2) In order to investigate the field uniformity, the vertical magnetic field was measured in a large area around the magnet axis. The field normalized to its central value (B/B_0) as a function of the distance from the axis is shown in Fig. 5 for different vertical displacements in the vacuum chamber.

The same measurements (B/B_0 vs. x,y) are shown in a three-dimensional plot in Fig. 6.

- 3) In Fig. 7 the fringing fields are shown at the coil short circuit end and at the feed-troughs end.

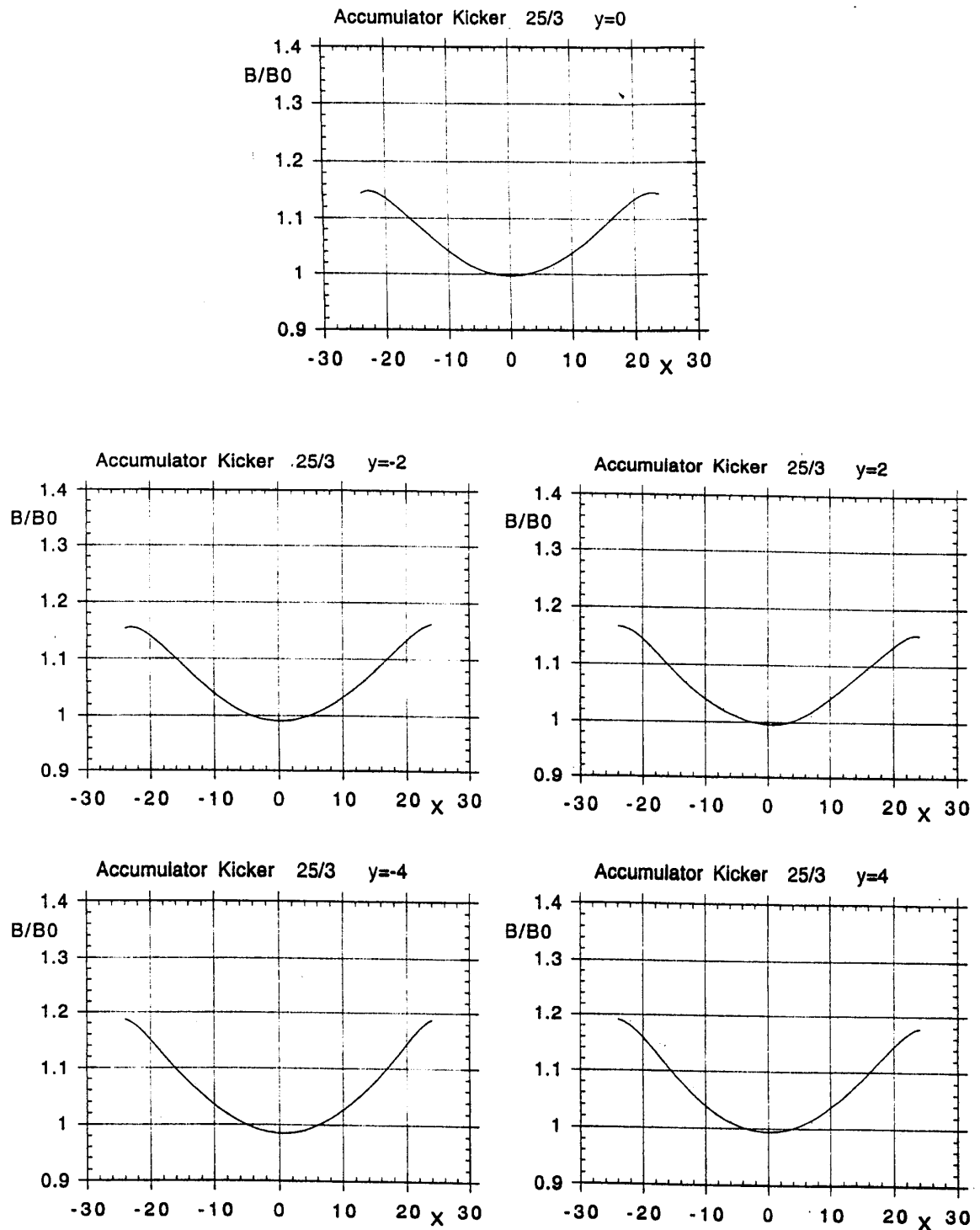

Fig. 5 - Measured ratio of the center value versus the distance X (mm) from the axis
 a) $Y=0$, b) $Y=-2$ mm, c) $Y=-4$ mm, d) $Y=2$ mm, e) $Y=4$ mm.

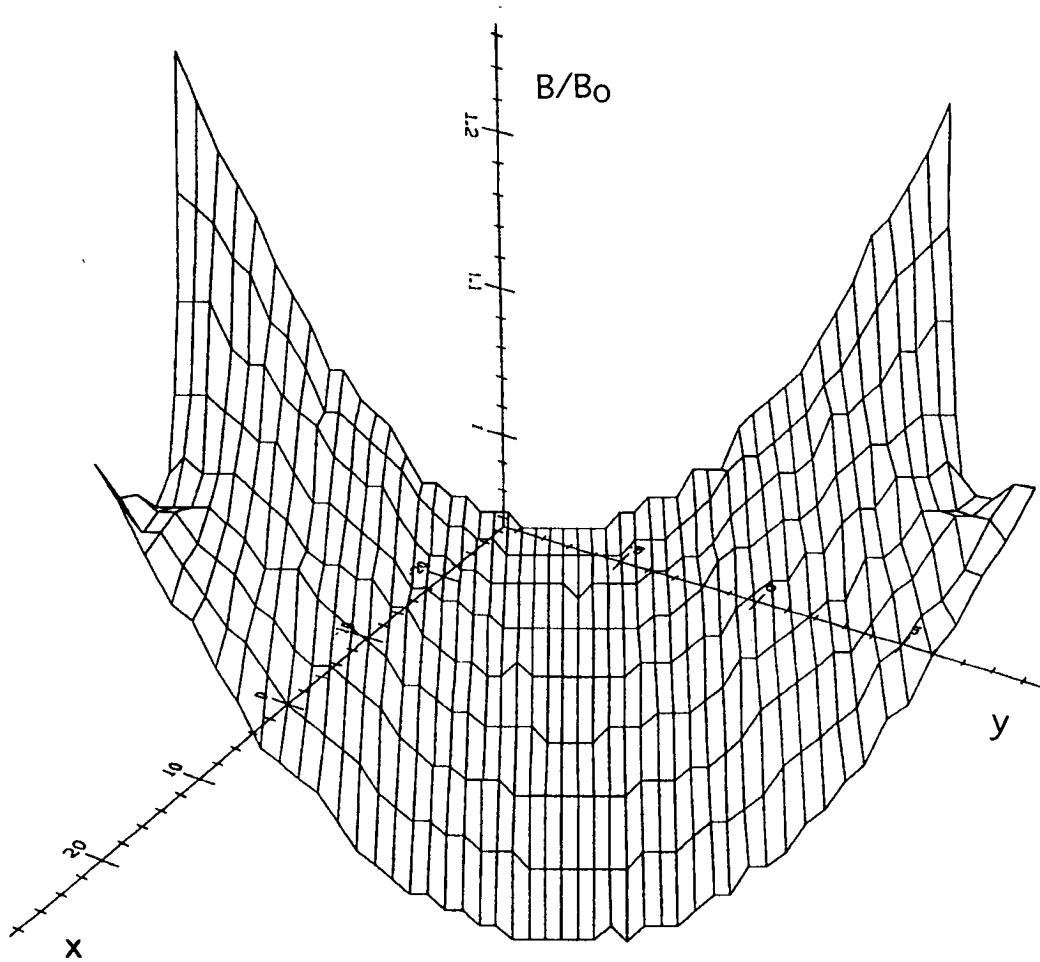

Fig. 6 - Tridimensional plot of the measured magnetic field.

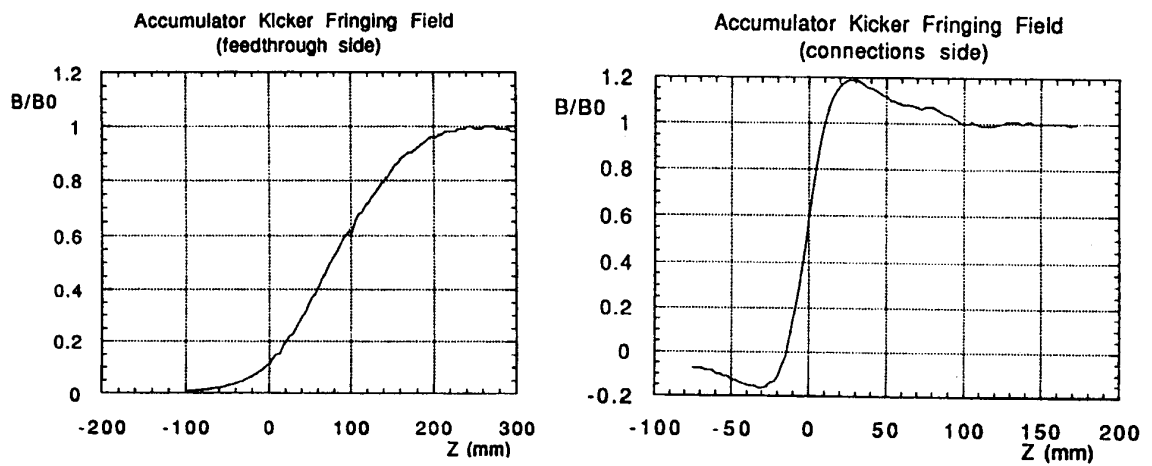

Fig. 7 - Measured ratio of the center value versus the longitudinal coordinate in the fringe range. a) Feed-through side; b) Bar connections side.

7. Conclusion

The magnetic measurements show that the displacement of the stored beam at injection (7 mm) is in the range of ± 10 mm good uniformity.

With the measured field value shown before, the maximum required pulser current must be ~ 2.6 KA at extraction.

The high voltage, full repetition rate tests are in progress in the Pulsed Magnet Laboratory with the prototype under vacuum.

8. Acknowledgments

We would like thank H. Hsieh and the Mechanical Engineer Section of the Accelerator Division for the engineering of the kicker magnet, F. Rubeo and the Electronic Laboratory for the experimental set-up realization, M.Troiani for the alignment of the measurement coils and outstanding P. Possanza for her assistance in the preparation of this note.

References

- 1) M.A. Preger: "A Positron and Electron Accumulator for DAΦNE", DAΦNE Technical Note I-1, 15/11/90.
- 2) M.R. Masullo, C. Milardi, M.A. Preger: "DAΦNE Accumulator Update-3", DAΦNE Technical Note I-9, 13/5/92.
- 3) S. De Simone, A. Ghigo: "DAΦNE Accumulator Kickers", 3th European Particle Accelerator Conference Proceedings, Berlin, 24-28 March 1992 p.1449.
- 4) L. Pellegrino, "Mechanical analysis of the DAΦNE accumulator kickers", DAΦNE Technical Note ME-2, 28/1/93.